

DRG.NO EF160L-B3

FRAME EF160L

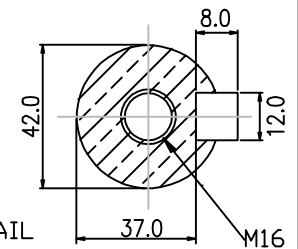

59 PEEL ROAD  
O'CONNOR WA 6163  
Ph: (08) 9314 7666  
Fax: (08) 9337 2505  
www.ems-perth.com

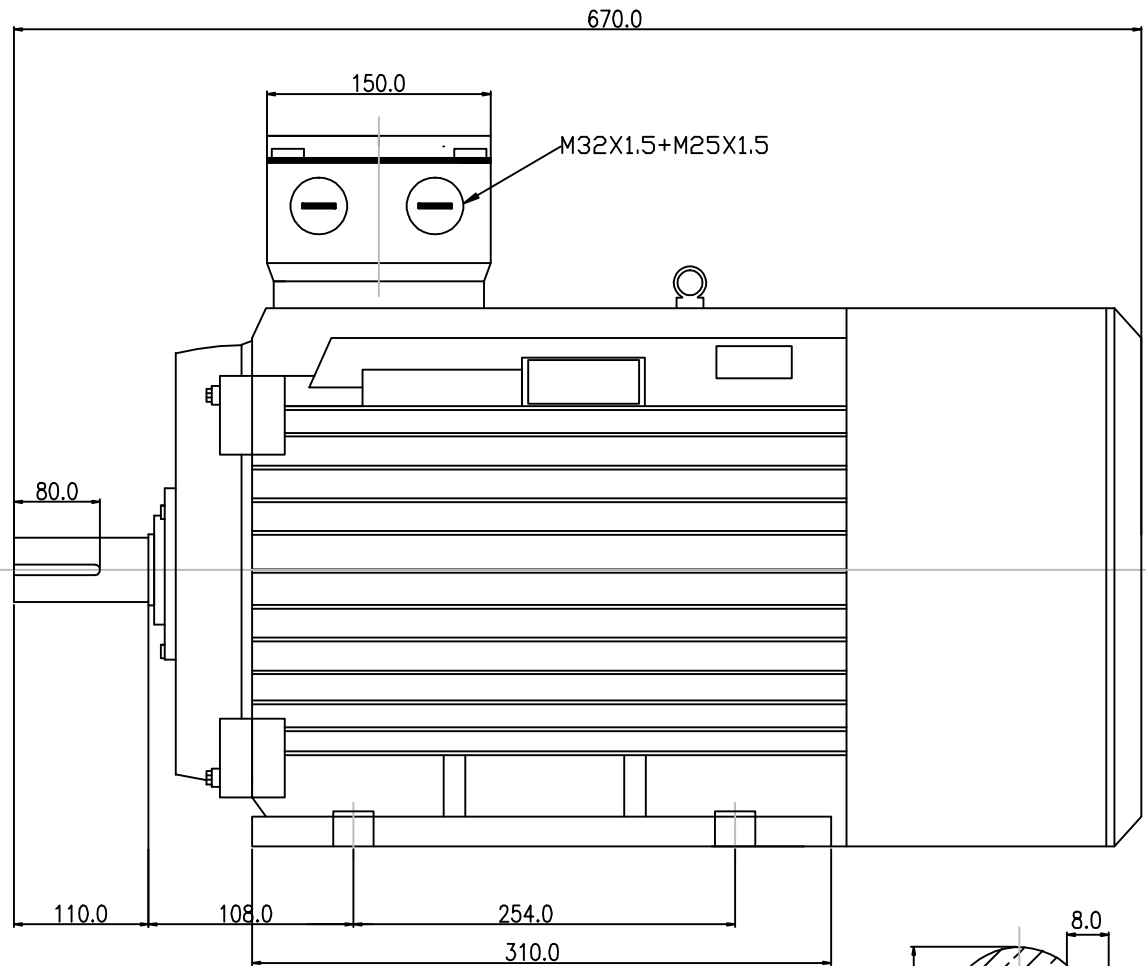
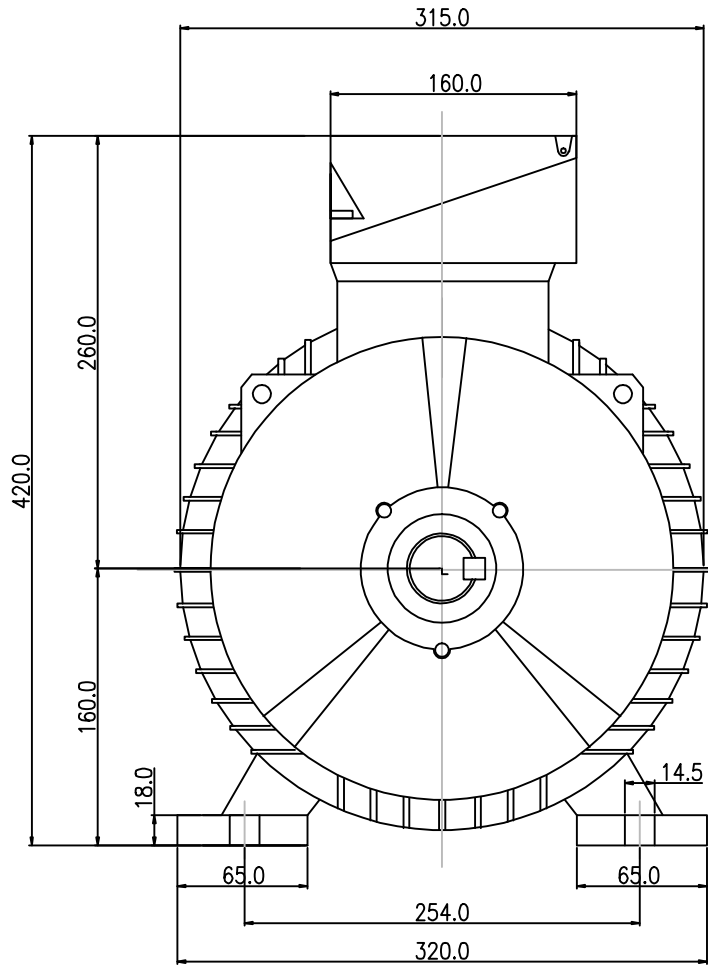

DRAFTING STANDARD AS 1100

SIZE A4

ALL DIMENSIONS ARE IN mm UNLESS OTHERWISE SPECIFIED  
TOL. 1 PLACE DECIMAL ± 0.25 ANGLE ± 0.30°  
2 PLACE DECIMAL ± 0.13

MATL SPEC

TITLE  
THREE PHASE INDUCTION MOTORS-TOP TERMINAL BOX  
(FOOT MOUNT B3 EF160L)

DRN	NL	DATE	5.12.08
CHK		APPD	
SCALE	NTS		

DESCRIPTIONS

BRAND	<b>REM X</b>	
DRG NO	EF160L-B3	REV
CODE No.		