

DRG.NO

EF225M-8-B3

FRAME

EF225M-8

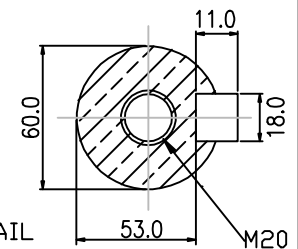
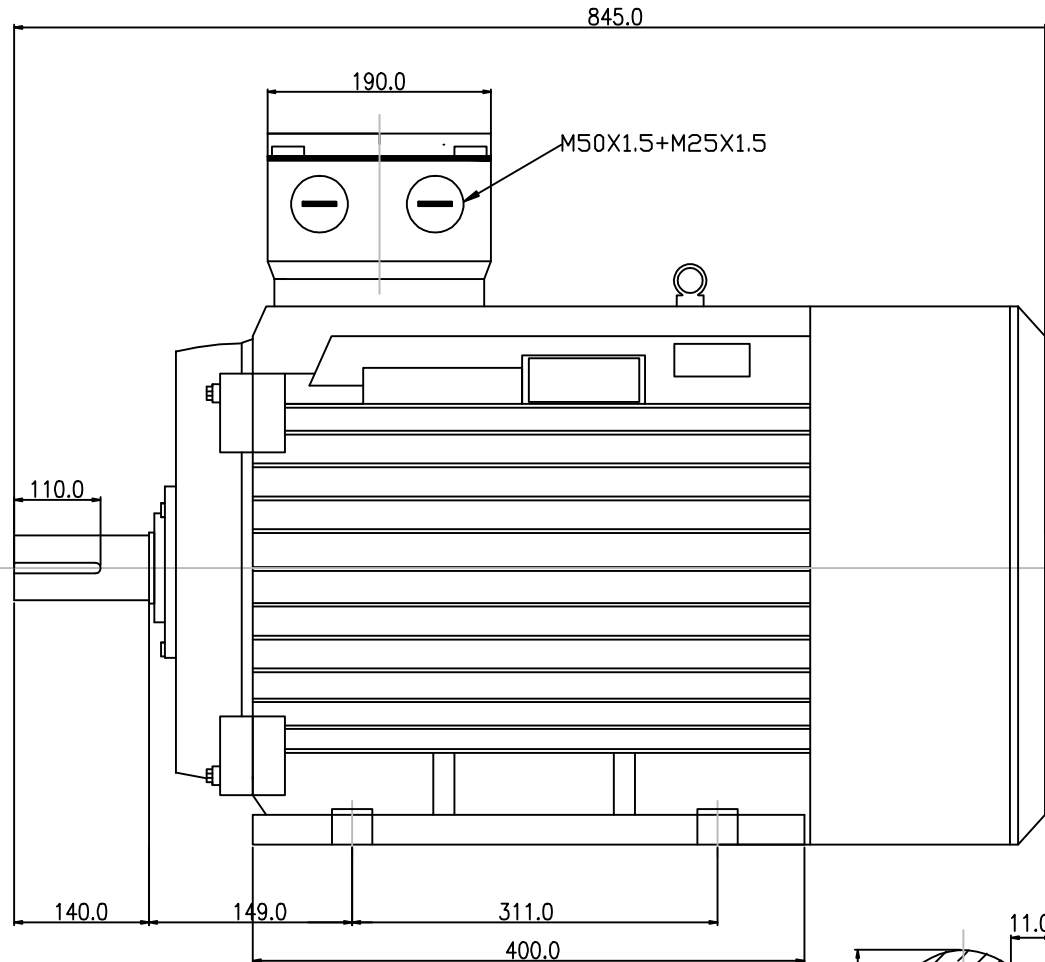
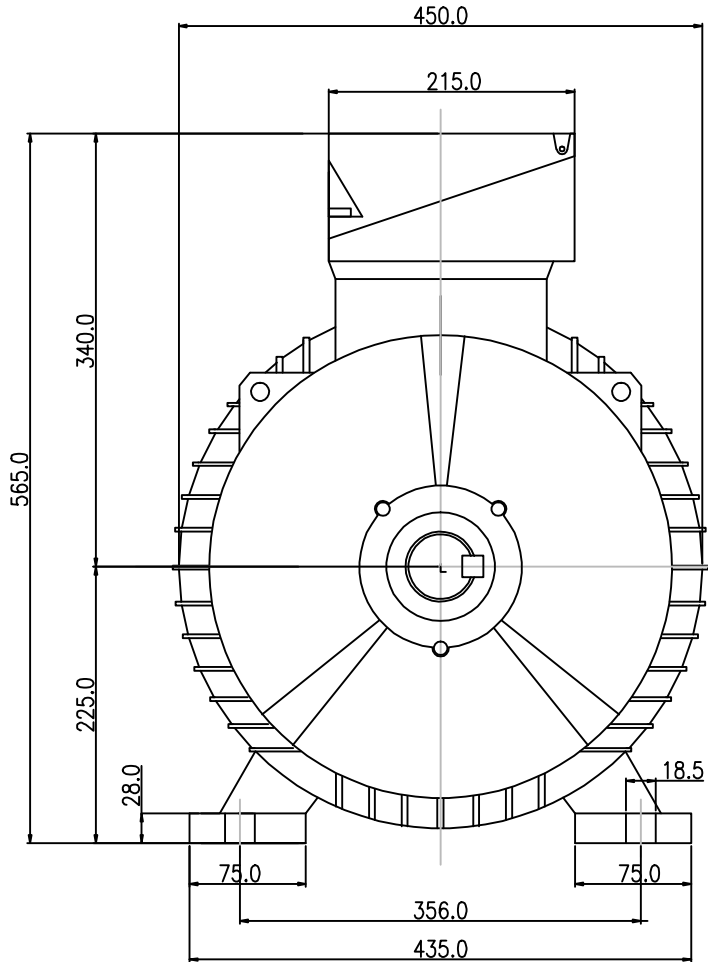

SHAFT DETAIL



59 PEEL ROAD
O'CONNOR WA 6163
Ph: (08) 9314 7666
Fax: (08) 9337 2505
www.ems-perth.com



DRAFTING
STANDARD
AS 1100

SIZE
A4

ALL DIMENSIONS ARE IN mm
UNLESS OTHERWISE SPECIFIED
TOL. 1 PLACE DECIMAL ± 0.25 ANGLE $\pm 0.30^\circ$
2 PLACE DECIMAL ± 0.13

MATL SPEC

TITLE
THREE PHASE INDUCTION MOTORS-TOP TERMINAL BOX
(FOOT MOUNT B3 EF225M-8)

DRN	NL	DATE	4.12.08
CHK		APPD	
SCALE	NTS		

DESCRIPTIONS
SHAFT TYPE EF225-8

BRAND



DRG NO EF225M-8-B3 REV

CODE No.