

DRG.NO

EF280S-2-B3

FRAME

EF280S-2

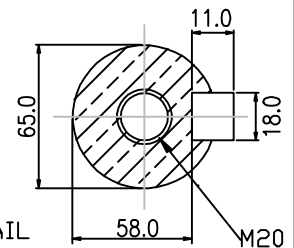
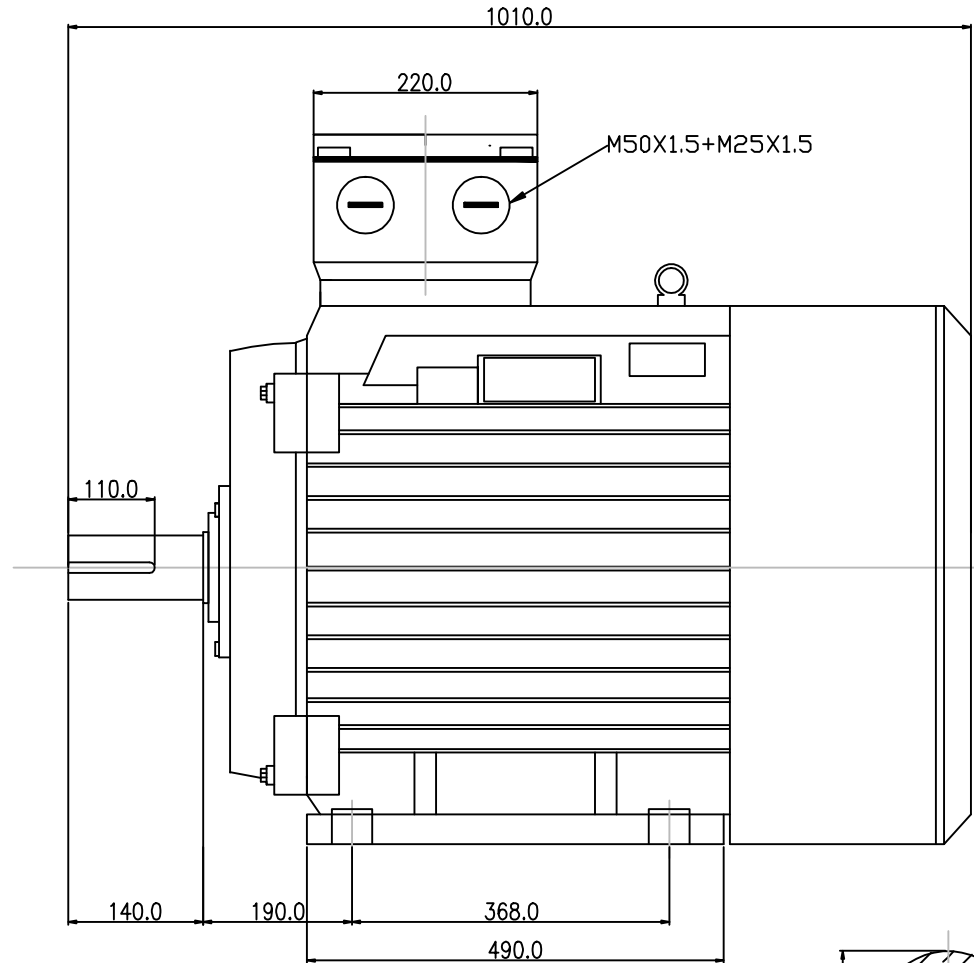
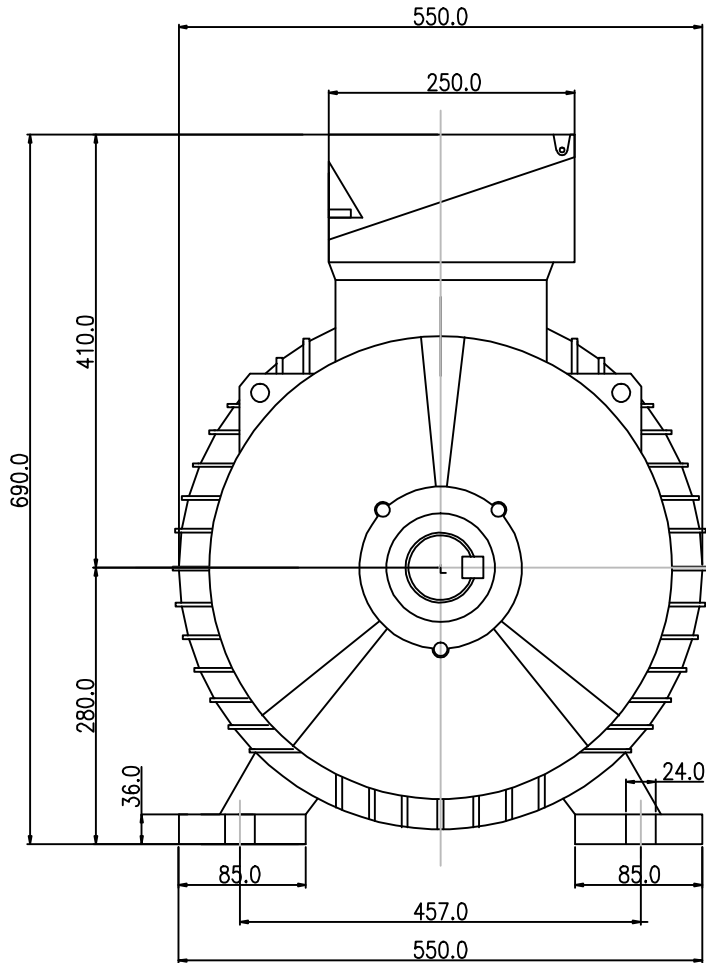

SHAFT DETAIL



59 PEEL ROAD
O'CONNOR WA 6163
Ph: (08) 9314 7666
Fax: (08) 9337 2505
www.ems-perth.com



DRAFTING
STANDARD
AS 1100

SIZE
A4

ALL DIMENSIONS ARE IN mm
UNLESS OTHERWISE SPECIFIED
TOL. 1 PLACE DECIMAL ± 0.25 ANGLE $\pm 0.30'$
2 PLACE DECIMAL ± 0.13

MATL

SPEC

TITLE

THREE PHASE INDUCTION MOTORS-TOP TERMINAL BOX
(FOOT MOUNT B3 EF280S-2)

DRN	NL	DATE	8.12.08
CHK		APPD	
SCALE	NTS		

DESCRIPTIONS

SHAFT TYPE EF280-2

BRAND



DRG NO

EF280S-2-B3

REV

CODE No.