

DRG.NO

EF315L-2-B3

FRAME

EF315L-2

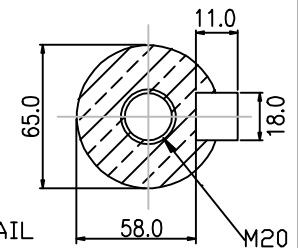
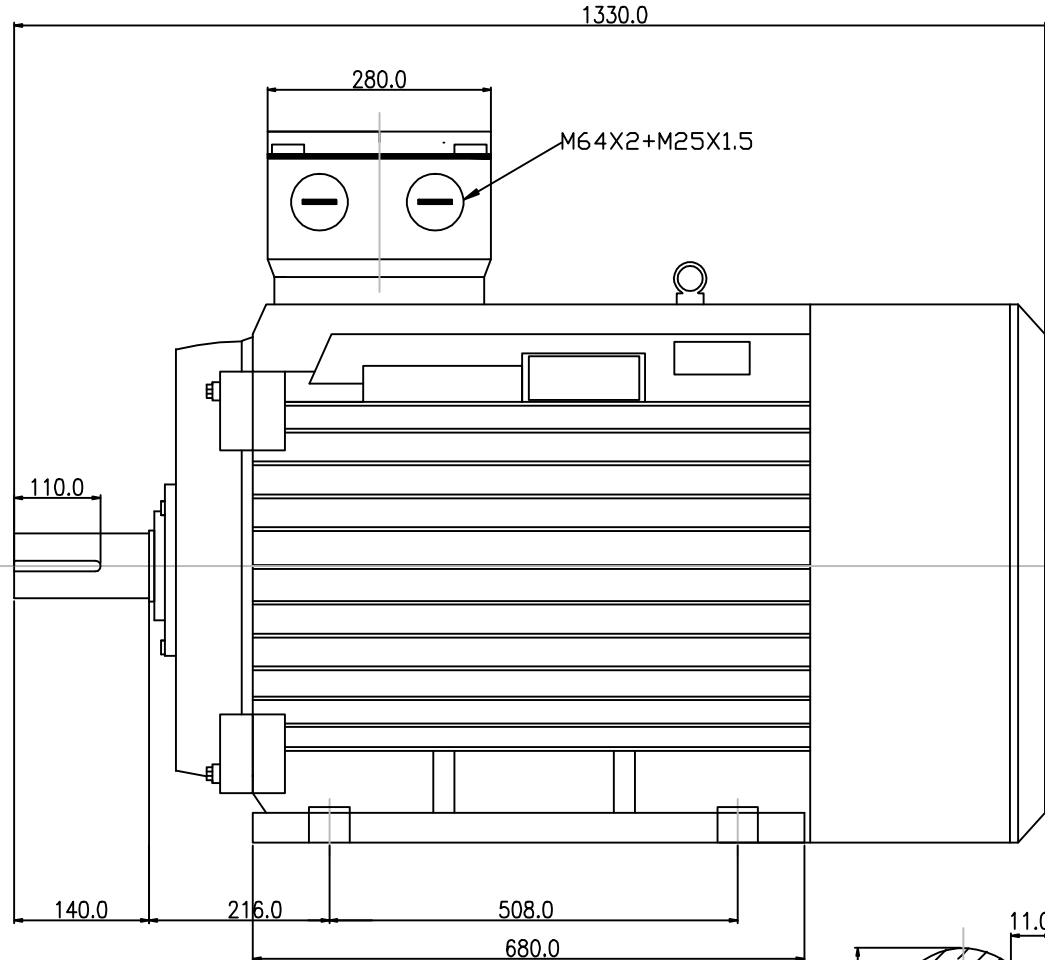
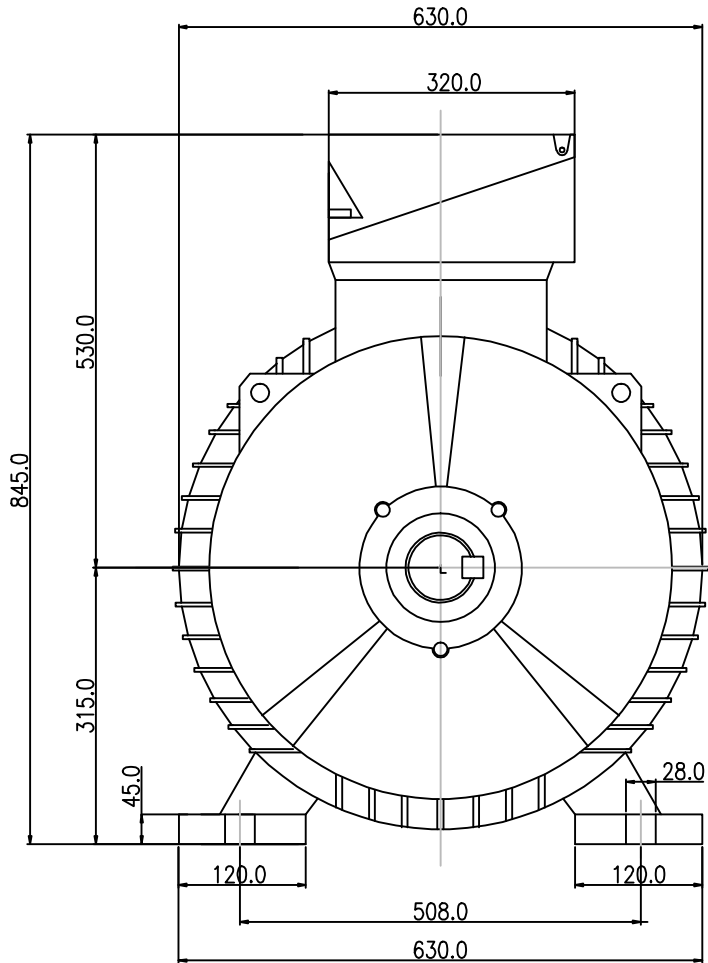

SHAFT DETAIL



59 PEEL ROAD  
O'CONNOR WA 6163  
Ph: (08) 9314 7666  
Fax: (08) 9337 2505  
www.ems-perth.com



DRAFTING  
STANDARD  
AS 1100

SIZE  
A4

ALL DIMENSIONS ARE IN mm  
UNLESS OTHERWISE SPECIFIED  
TOL. 1 PLACE DECIMAL  $\pm 0.25$  ANGLE  $\pm 0.30^\circ$   
2 PLACE DECIMAL  $\pm 0.13$

MATL SPEC

TITLE  
THREE PHASE INDUCTION MOTORS-TOP TERMINAL BOX  
(FOOT MOUNT B3 EF315L-2)

DRN	NL	DATE	4.12.08
CHK		APPD	
SCALE	NTS		

DESCRIPTIONS  
SHAFT TYPE EF315-2

BRAND

**REM X**

DRG NO

EF315L-2-B3

REV

CODE No.