

DRG.NO EF355M-6-B3

FRAME EF355M-6

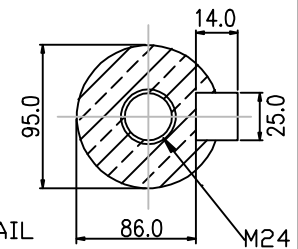

SHAFT DETAIL

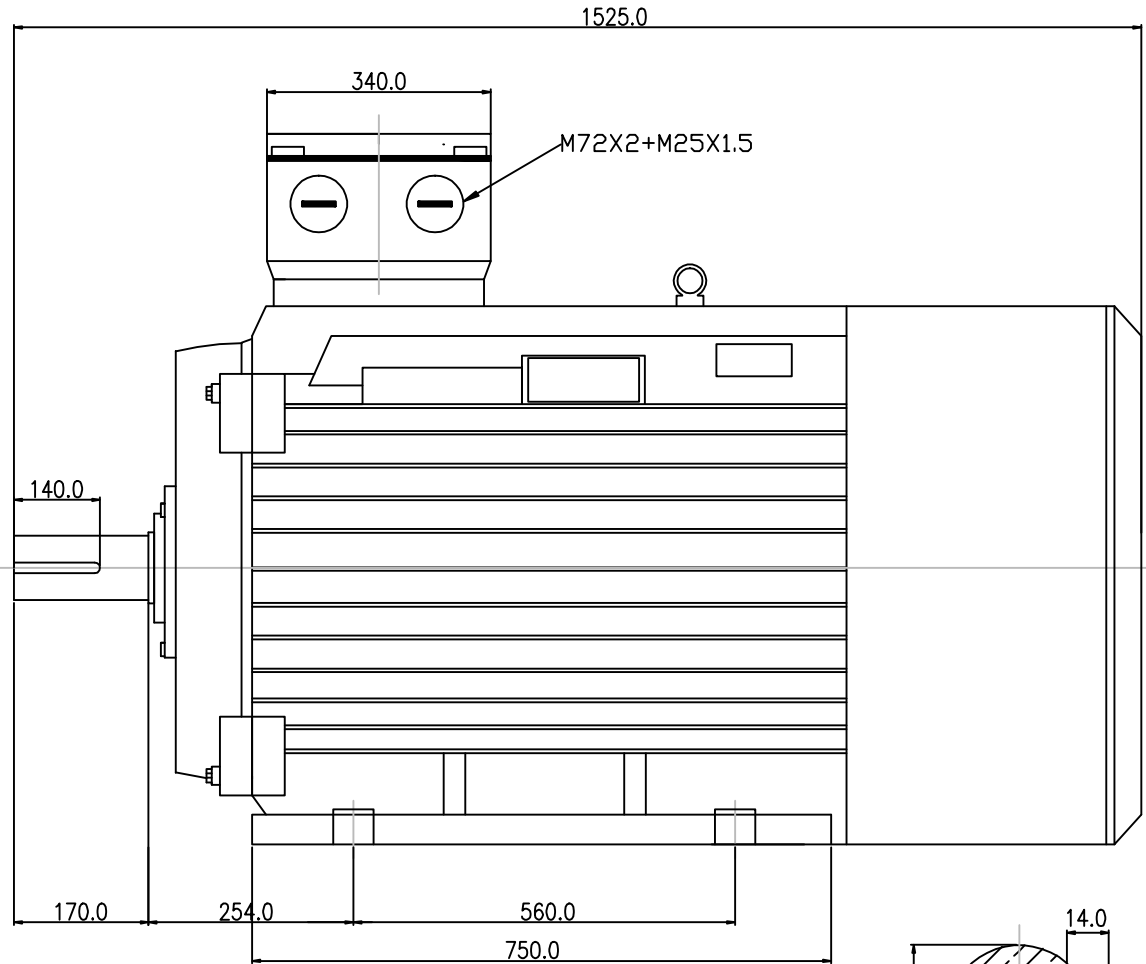
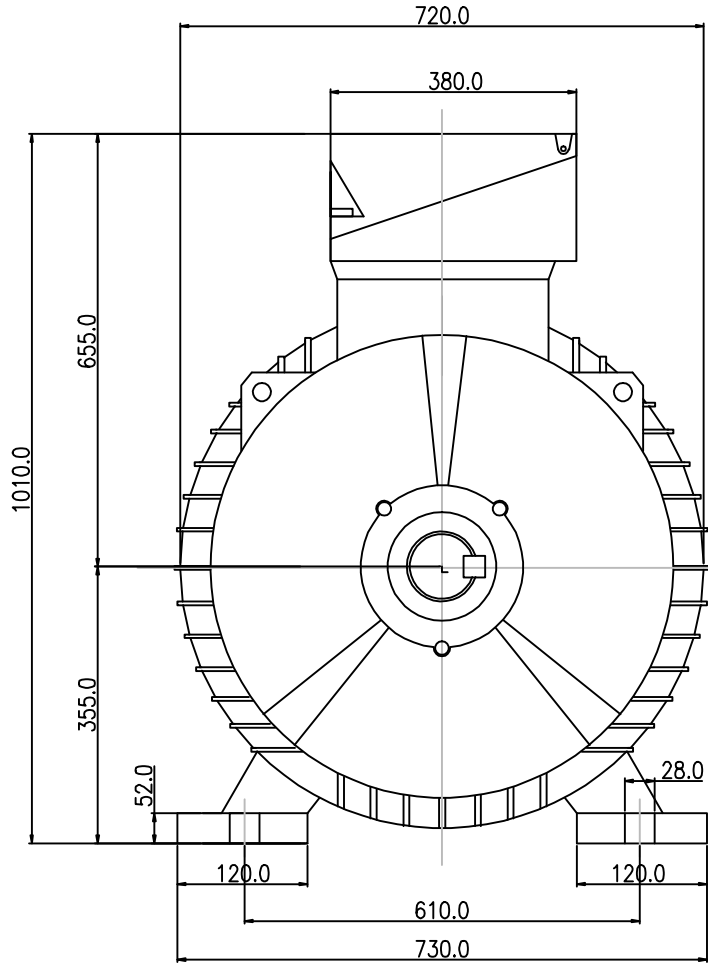

59 PEEL ROAD  
O'CONNOR WA 6163  
Ph: (08) 9314 7666  
Fax: (08) 9337 2505  
www.ems-perth.com



DRAFTING  
STANDARD  
AS 1100

SIZE  
A4

ALL DIMENSIONS ARE IN mm  
UNLESS OTHERWISE SPECIFIED  
TOL. 1 PLACE DECIMAL  $\pm 0.25$  ANGLE  $\pm 0.30'$   
2 PLACE DECIMAL  $\pm 0.13$

MATL SPEC

TITLE  
THREE PHASE INDUCTION MOTORS-TOP TERMINAL BOX  
(FOOT MOUNT B3 EF355M-6)

DRN	NL	DATE	9.12.08
CHK		APPD	
SCALE	NTS		

DESCRIPTIONS  
SHAFT TYPE EF355-6

BRAND	<b>REM X</b>	
DRG NO	EF355M-6-B3	REV
CODE No.		